

KDR-1: Dashcam Adapter Wiring

KDR-1 IS INCLUDED WITH:
1480S(B)-DR

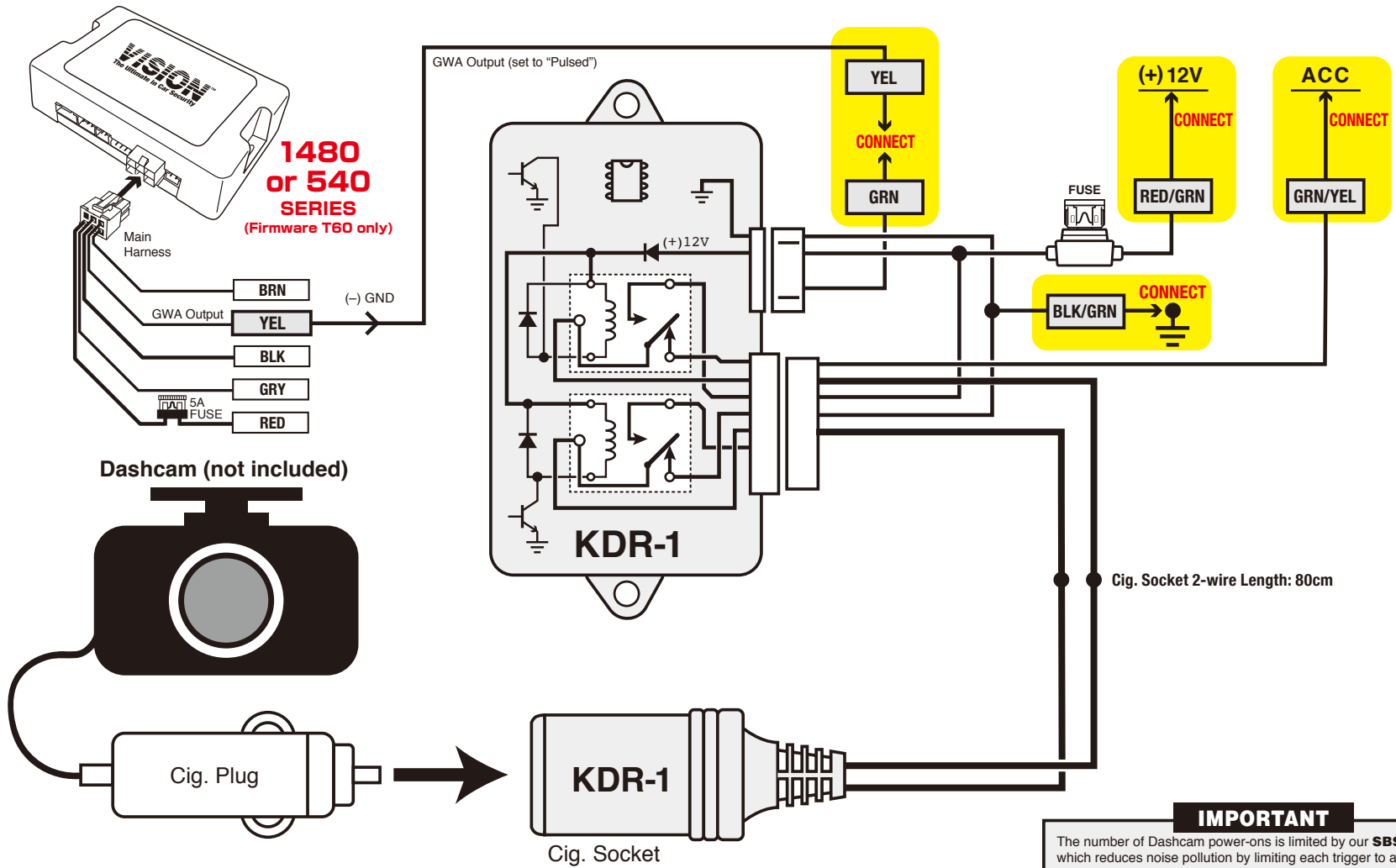

IMPORTANT

The number of Dashcam power-ons is limited by our **SBS** feature which reduces noise pollution by limiting each trigger to a max of 10 times. The Dashcam can be powered on (to record) for up to 10 full siren blast triggers and 10 warning chip triggers per Arming session. **NOTE: Sensor Bypass Mode** disables Dashcam power-ons!